

DRAWING NUMBER: 1108414
 REVISION: G

CABLE CUTTING
 CABLE SOURCE :
 1. TA TUN(DONG GUAN).

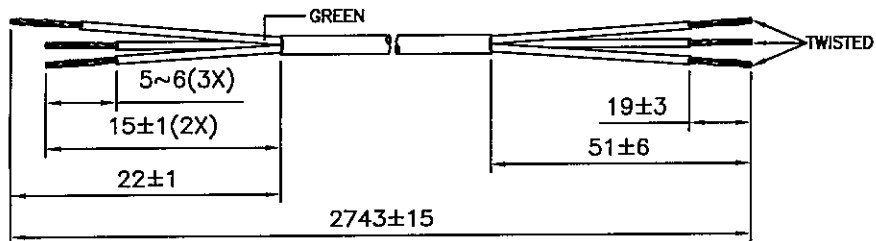

ASSEMBLY :

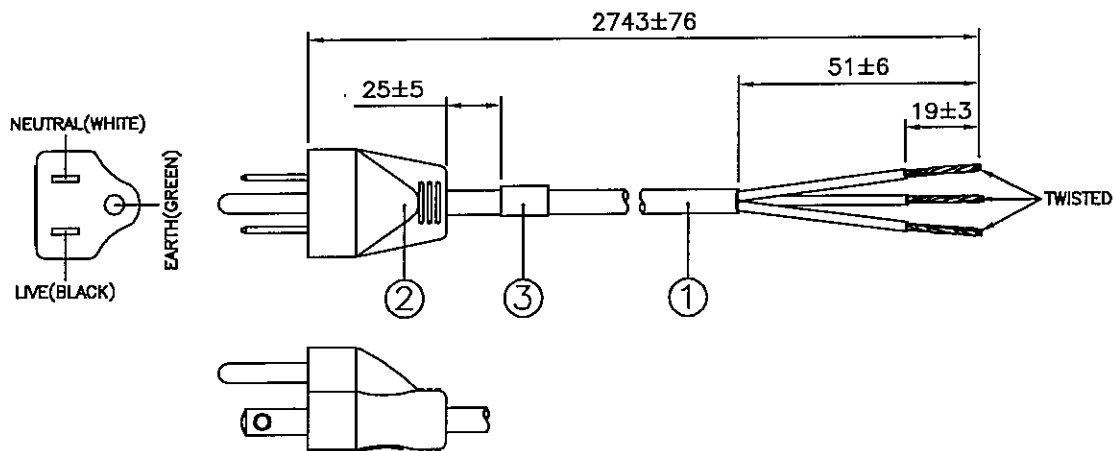

Notes :

1. ALL DIMENSIONS IN mm.
2. PLUG MARKING : REFER TO MARKING DRAWING NO. : VP-0108M.
3. PLUG DETAILS : REFER TO PRODUCT DRAWING NO. : P-0146.
4. THIS PART CAN BE MANUFACTURED AT ANY LOCATION WHICH HAS SAFETY APPROVAL.
5. LABEL DETAILS : REFER TO LABEL DRAWING NO. : VL-0234.

REV.	ECR REF. NO.	DESCRIPTION	DATE
		CHANGE PLUG ITEM NO. FM. 'PS204-15R' TO 'PS204D-15R'.	
		CHANGE PLUG PRODUCT DWG. FM. 'P-0045' TO 'P-0146'.	
F	140152	CHANGE PLUG MARKING DWG. FM. 'VP-0108' TO 'VP-0108C'.	16/04/14
G	150232	CHANGE PLUG MARKING DWG. FM. 'VP-0108C' TO 'VP-0108M'.	12/05/15

3	PRINTED LABEL	VL-0234	1
	IP40G NL792B BLK	4100017	-
2	MOLDED PLUG PS204D (15A 125V)	PS204D-15R	1
1	SJO 14/3 90°C BWG BLK	1921005	2.743M

S/N	DESCRIPTION	ITEM NUMBER	QTY
TITLE : NORTH-AMERICAN POWER SUPPLY CORD (CS-LF0001)		PAGE : 1/2	
CUSTOMER : VIS/VOLEX INC		HG10-267-07	
CUSTOMER PART NUMBER : 17629 1Ø B1		DWG. TYPE	
F/G CODE : 17629 1Ø B1		SPEC NO.: --- OED	

SALES : N.A.	QA : N.A.	ENGRG : Feng	CHECKED BY : Ashly	DRAWN BY : ASHLY	Volex (Asia) Pte Ltd <small>Confidential property of Volex. Information contained herein shall not be disclosed in whole, reproduced or used for any other purposes except as authorized in writing by an authorized official of Volex Asia.</small>
DATE : N.A.	DATE : N.A.	DATE : 14/05/15	DATE : 14/05/15	DATE : 12/05/15	

DRAWING NUMBER :

1108414

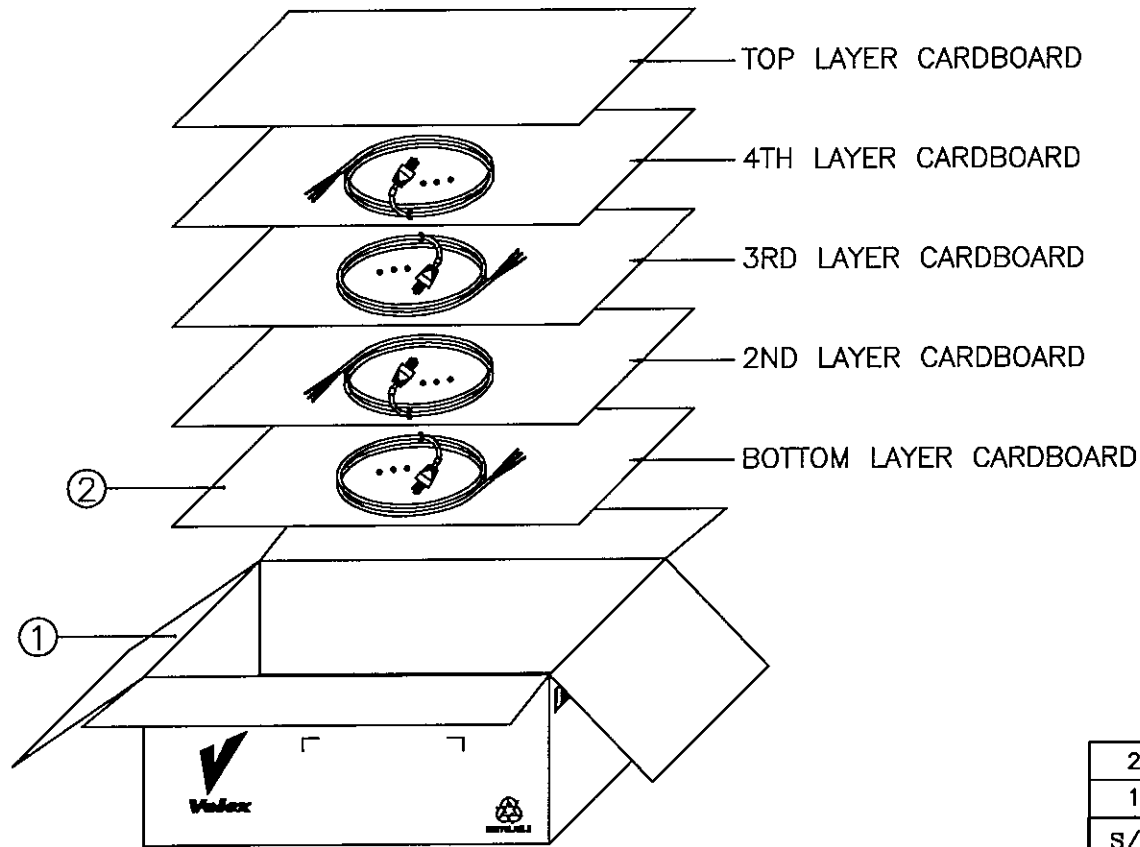

PACKAGING INSTRUCTION

1. 10 PCS PER BUNDLE, 1 BUNDLE PER LAYER, 4 LAYERS PER CARTON.
2. ALL CORDS LAYOUT AS DETAIL.
3. PACKAGING : 40 PCS PER CARTON.

NOTE :

1.) ALL DIMENSIONS IN mm.

2	CARTON PAPER 550X305MM	901024	0.125
1	LONG CARTON 560X330X250MM	901011	0.025
S/N	DESCRIPTION	ITEM NUMBER	QTY
REVISION	G	TITLE : PACKAGING SPEC.	
PAGE	2/2		
SCALE	N.T.S.		
REFERENCE :		Volex (Asia) Pte Ltd	
DESCRIPTION : CARTON BOX		<small>Confidential property of Volex. Information contained herein shall not be disclosed to others, reproduced or used for any other purposes except as authorized in writing by an authorized official of Volex Asia.</small>	